



for a greener tomorrow



**MITSUBISHI
ELECTRIC**

Changes for the Better

FACTORY AUTOMATION

Simple Solution Catalog

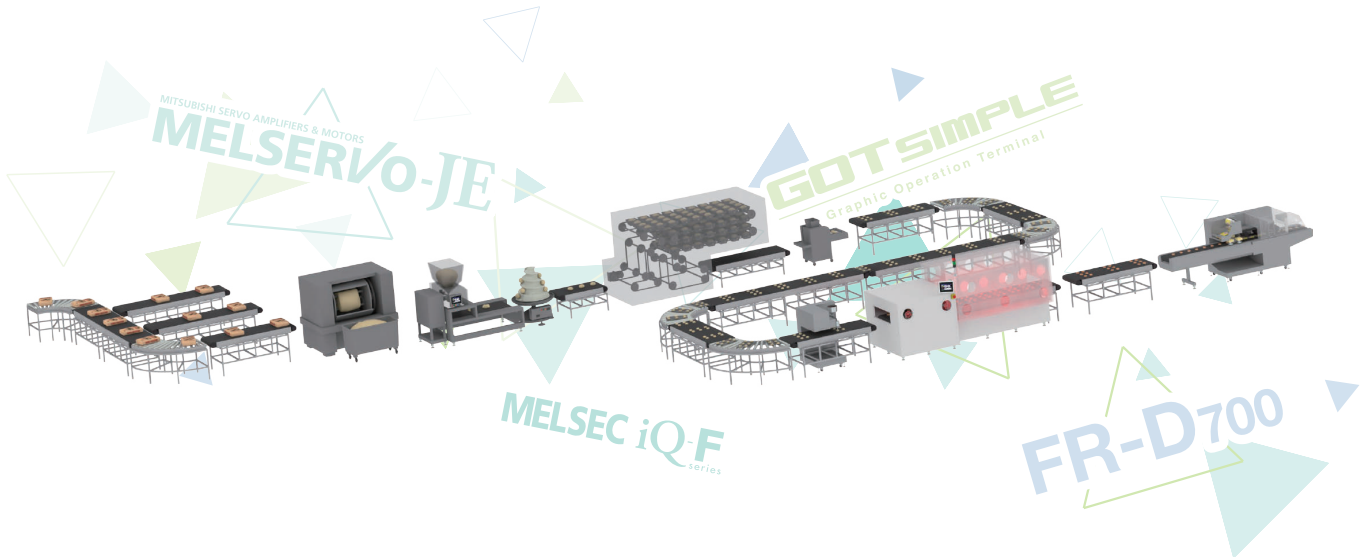

SIMPLE SOLUTIONS



GLOBAL IMPACT OF MITSUBISHI ELECTRIC



Through Mitsubishi Electric's vision, "Changes for the Better" are possible for a brighter future.

Changes for the Better

We bring together the best minds to create the best technologies. At Mitsubishi Electric, we understand that technology is the driving force of change in our lives. By bringing greater comfort to daily life, maximizing the efficiency of businesses and keeping things running across society, we integrate technology and innovation to bring changes for the better.

Mitsubishi Electric is involved in many areas including the following

Energy and Electric Systems

A wide range of power and electrical products from generators to large-scale displays.

Electronic Devices

A wide portfolio of cutting-edge semiconductor devices for systems and products.

Home Appliance

Dependable consumer products like air conditioners and home entertainment systems.

Information and Communication Systems

Commercial and consumer-centric equipment, products and systems.

Industrial Automation Systems

Maximizing productivity and efficiency with cutting-edge automation technology.

INDEX

Mitsubishi Electric Industrial Devices Simple Solutions Guide	4
01 Material handling Easy and simple control with inverters	6
02 Production 1 Simple positioning control with GOT and servo	8
02 Production 2 Smooth drive control with Simple Motion and servo	10
02 Production 3 Connectivity with Mitsubishi Electric industrial devices for easy automation	12
03 Packaging Easily build a network with Mitsubishi Electric AC Servo	14
Mitsubishi Electric Industrial Devices Guide	16
Inverter FR-D700	16
Programmable Controller MELSEC iQ-F Series	18
AC Servo MELSERVO-JE	20
Graphic Operation Terminal GOT SIMPLE	22

Mitsubishi Electric Industrial Devices

Using Mitsubishi Electric industrial devices together provides ideal, simple solutions that enhance efficiency and reduce production costs.

01 Material handling

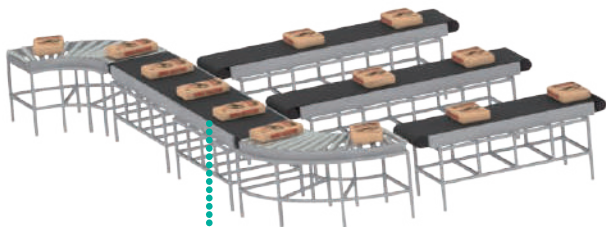

Recommended for simple control!



GOT SIMPLE



FR-D700

02 Production



Recommended for simple positioning control!



GOT SIMPLE



MR-JE-A

Simple Solutions

Recommended for smooth drive control!



GOT SIMPLE



FX5 CPU module
+ Simple Motion module



MR-JE-B

03 Packaging

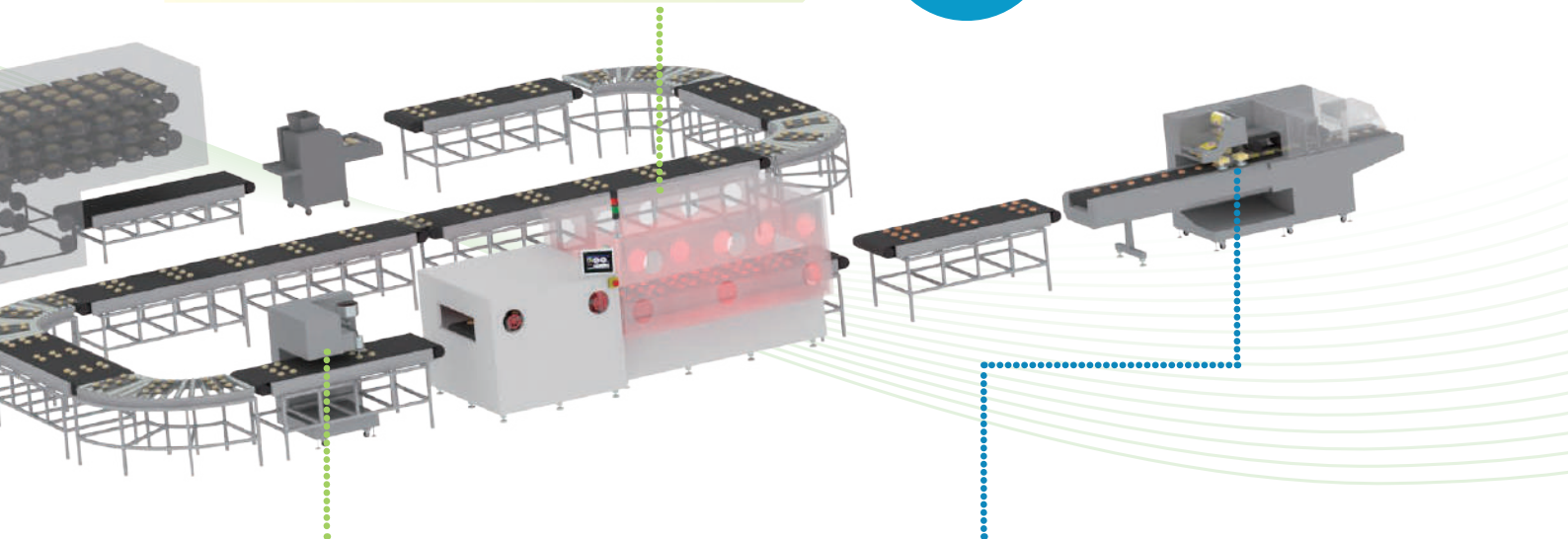

Recommended for easy automation!



GOT SIMPLE



FX5 CPU module



FR-D700

Recommended for building networks!



GOT SIMPLE



FX5 CPU module



MR-JE-C

01

Material handling

Easy and simple control with

GOT SIMPLE

FR-D700



RS-485



Point

Issue operation commands to inverter from the GOT.

3-phase motor

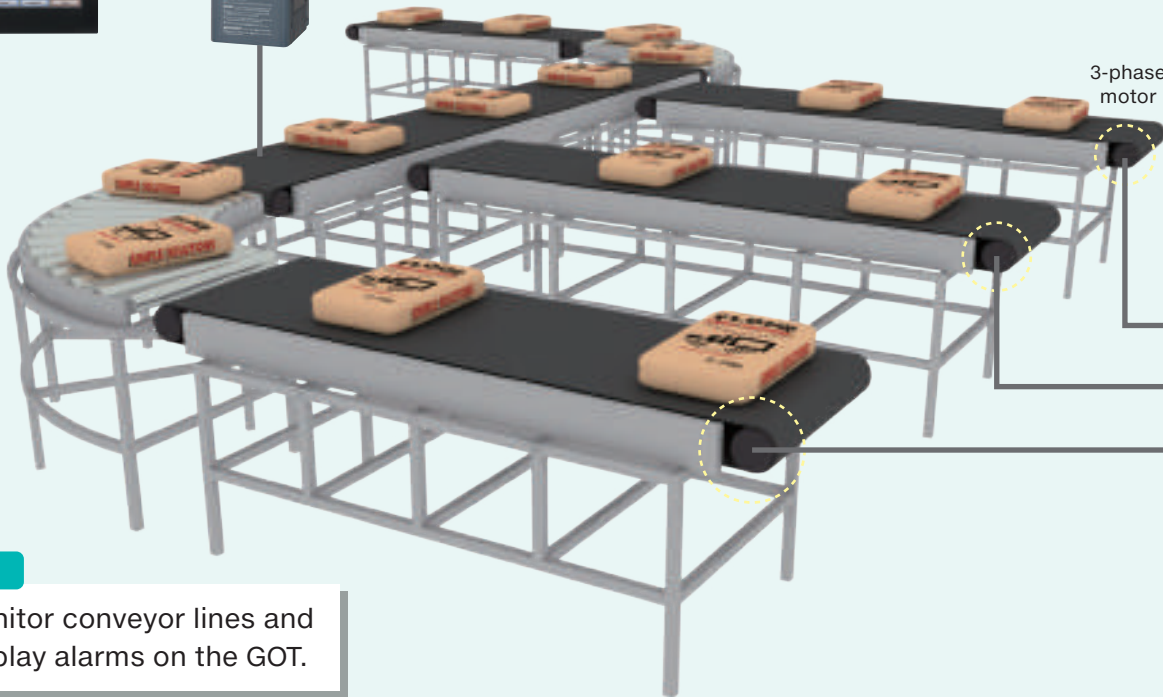

Point

Monitor conveyor lines and display alarms on the GOT.

Recommended functions for each application

FR-D700

General-purpose magnetic flux vector control

General-purpose magnetic flux vector control and auto tuning functions are available. These functions ensure the applications that require high starting torque, such as washing machines, agitators, and transfer machines including conveyors, hoists, and elevators.

- High torque of 150% / 1 Hz is realized (when the slip compensation function is valid).
- Auto tuning

With our “non-rotation” auto tuning function the motor constant (R1) can be automatically calculated.

Communication operation (RS-485 communication)

Conveyor belts can be controlled individually by using multiple inverters. Automatic operation is possible by collectively managing multiple inverters.

S-pattern acceleration/deceleration

An S-pattern is maintained from the present frequency to the target frequency; therefore it is possible to reduce shock during acceleration/deceleration and prevent load shifts.

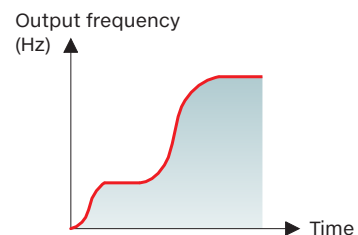

inverters

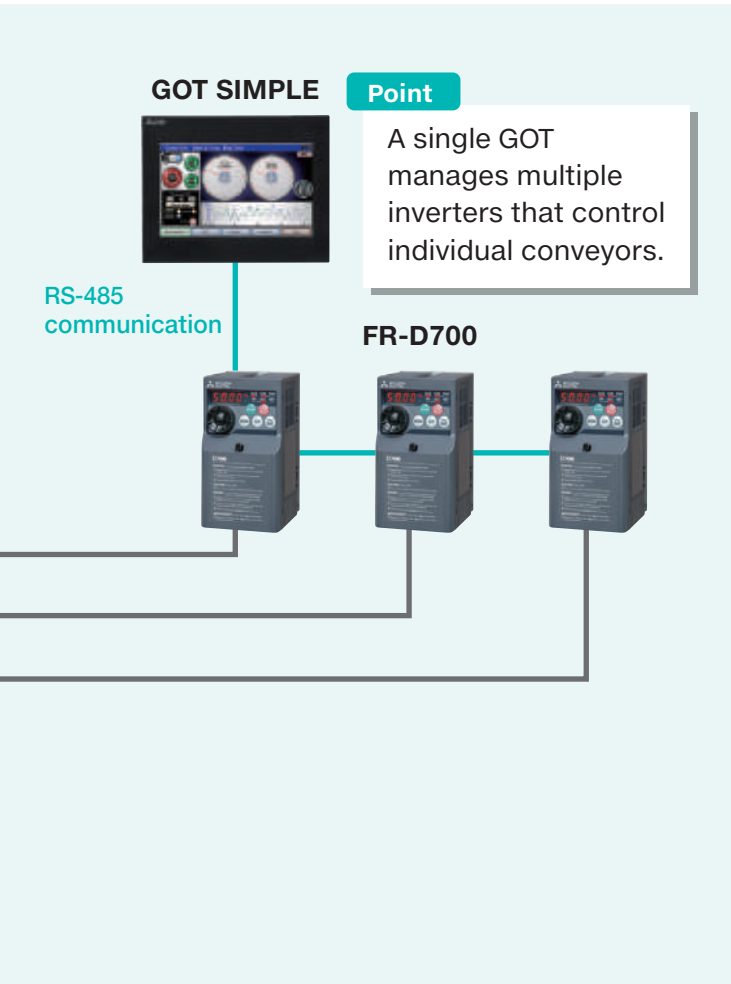

GOT SIMPLE

Recommended for simple control!

+

Inverter **FR-D700**



FR-D700 is an ideal choice

Application examples

Spinning



Recommended function: Traverse function
 The traverse function, used for the traverse axis of spinning machine, prevents uneven winding or collapsing.

Fan and pump



Recommended function: PID function
 Flow rate and air volume is controlled by an inverter. It is possible to regulate flow rate and air volume so that they stay at a pre-set level.

02

Production 1

Simple positioning control

Molding

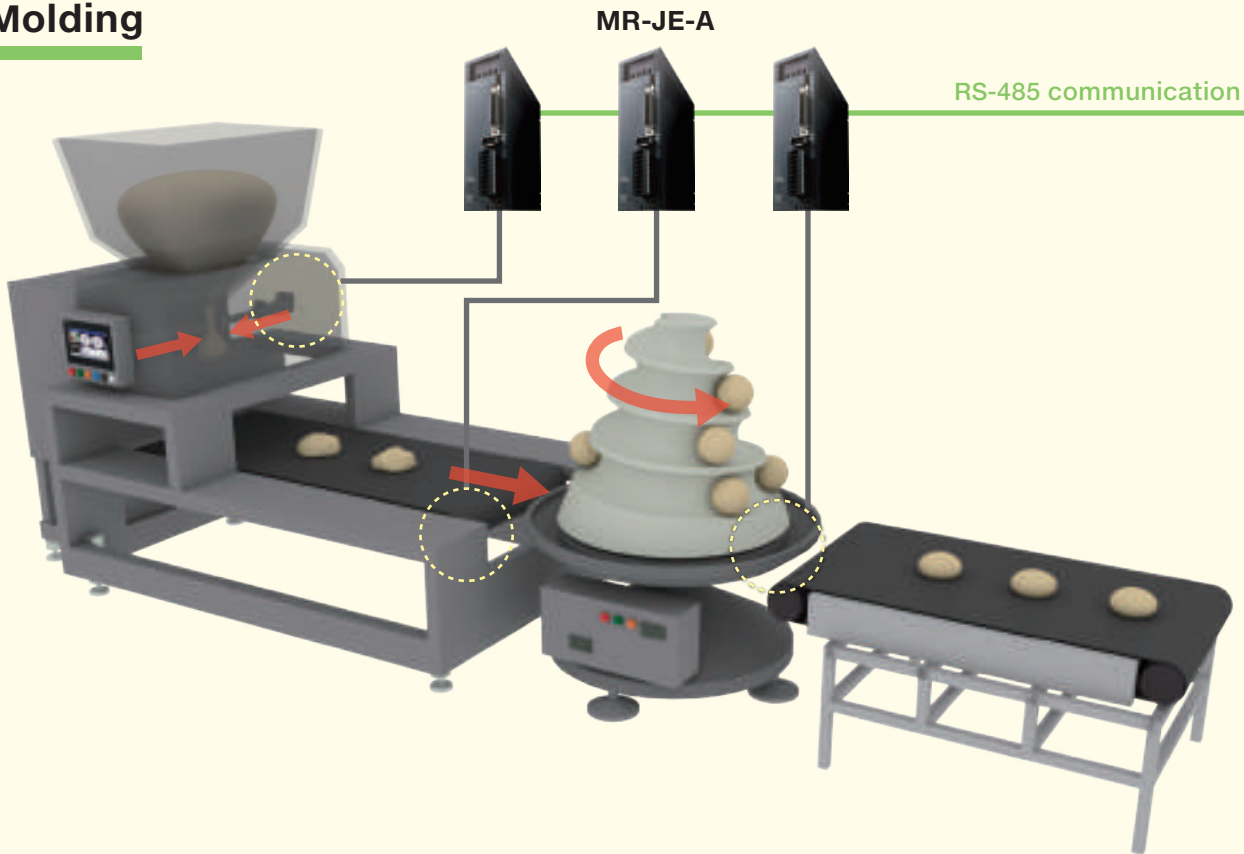

Recommended functions for each application

MR-JE-A

Simple cam function

Smooth conveyance and stopping are realized by cam control based on cam data. Cam operations include linear motion, reciprocating motion, and feeding motions, which can be selected according to your application.

+ MR Configurator2
Various patterns of cam data can be created easily.

Reciprocating motion	Linear motion	Feeding motion
<p>Reciprocating cam</p>	<p>Ball screw Rotary table</p>	<p>Belt conveyor Rotary table</p>
<p>Reciprocating cam motion within a cam stroke range</p>	<p>Linear cam motion by one cycle</p>	<p>Cam motion which resets a cam reference position per cycle</p>

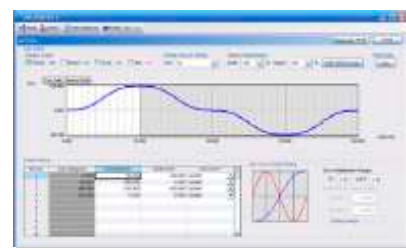

MR Configurator2
Simple cam setting window

with GOT and servo

GOT SIMPLE



Point

Positioning function is built into MR-JE-A. Directly connect to the GOT, and perform positioning and adjustments.



FX5 CPU module

FX5 CPU module has built-in high-speed I/O, and up to four MR-JE-A AC servos can be connected!

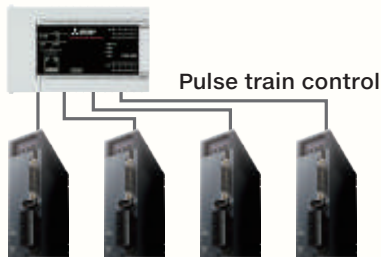

GOT SIMPLE



Recommended for simple positioning control!

AC Servo MELSERVO-JE

MR-JE-A



MR-JE-A is an ideal choice

Application examples

Rotary knife

Recommended function: Current position latch function and interrupt positioning function

The actual position of the servo motor can be obtained based on the inputs from the sensor that detects the registration marks printed on the high-speed moving film. The servo amplifier calculates compensation amounts and corrects position errors of the rotary knife axis based on those inputs from the sensor so that the film can be cut at the set position.

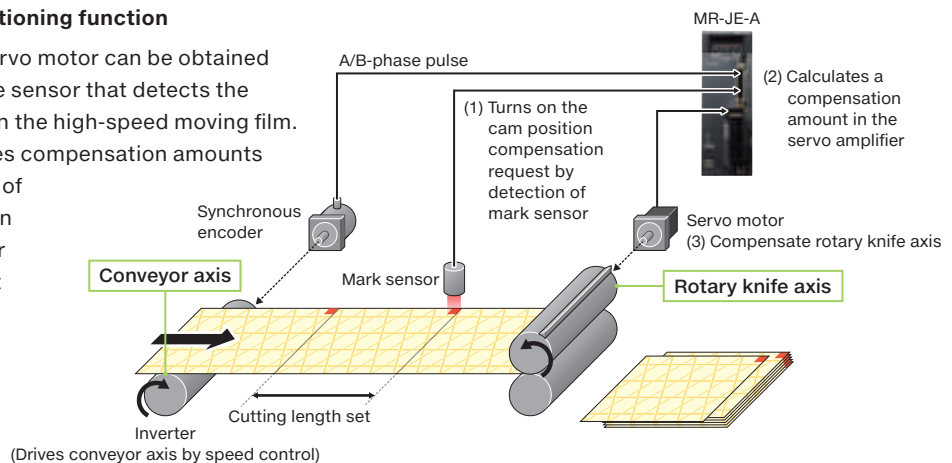

Filling machine

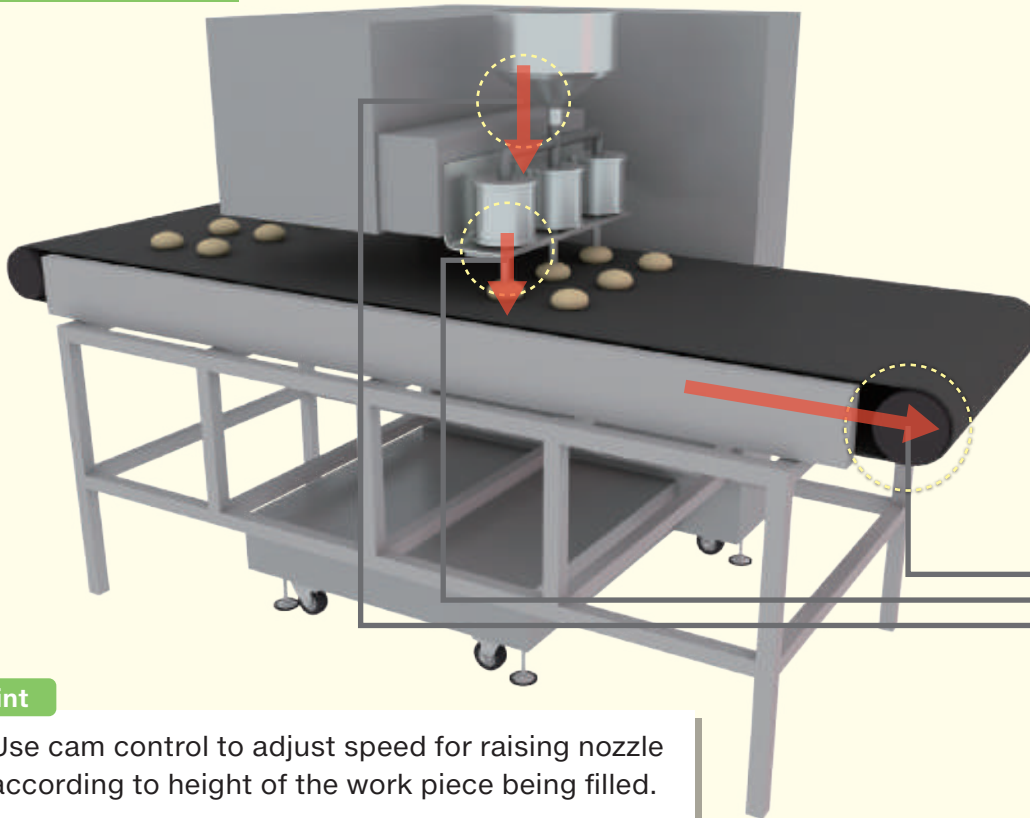

Point

Use cam control to adjust speed for raising nozzle according to height of the work piece being filled.

Recommended functions for each application

FX5 CPU module
+
Simple Motion module
+
MR-JE-B

Position, speed, torque control

Smoothly change to torque control mode from position/speed control mode without a stop or a sudden change in speed and torque, and thus reduce load to a machine. This function is ideal for applications where control switches from position to torque such as tightening & press-fit control or insertion of a work piece, and cap or screw tightening.

Deterministic and synchronized communication

Complete deterministic and synchronized communication is achieved with SSCNET III/H, offering technical advantages in machines such as printing and food processing machines that require synchronous accuracy.

Synchronous control without program

Just set parameters using software to easily realize synchronous control instead of controlling mechanically with physical gears, shafts, speed change gears or cams.

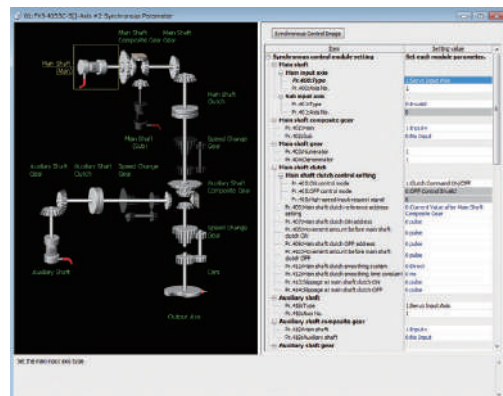

Simple Motion and servo

FX5 CPU module +
Simple Motion module



GOT SIMPLE



Ethernet



MR-JE-B



Recommended for
smooth drive control!

GOT SIMPLE



Programmable Controller MELSEC iQ-F Series

FX5 CPU module + Simple Motion module



AC Servo MELSERVO-JE

MR-JE-B



MR-JE-B
is an ideal choice

Point

Compatible with fiber optic network "SSCNET III/H", which accelerates system responsiveness.

Application examples

FX5 CPU module



Simple Motion module



Simplified machine tools

Unwinders & rewinders



SSCNET III/H allows configuration of a multi-axis synchronous control system even for unwinders & rewinders with multiple axes. For machines with a machining axis, further high-level synchronous control system is possible by using cam control and advanced synchronous control.



In positioning operation of XY table, the workpiece can be processed with high quality by using machine resonance suppression filter that suppresses machine vibration and lost motion compensation function that suppresses quadrant protrusion.

02

Production 3 Connectivity with Mitsubishi

Oven

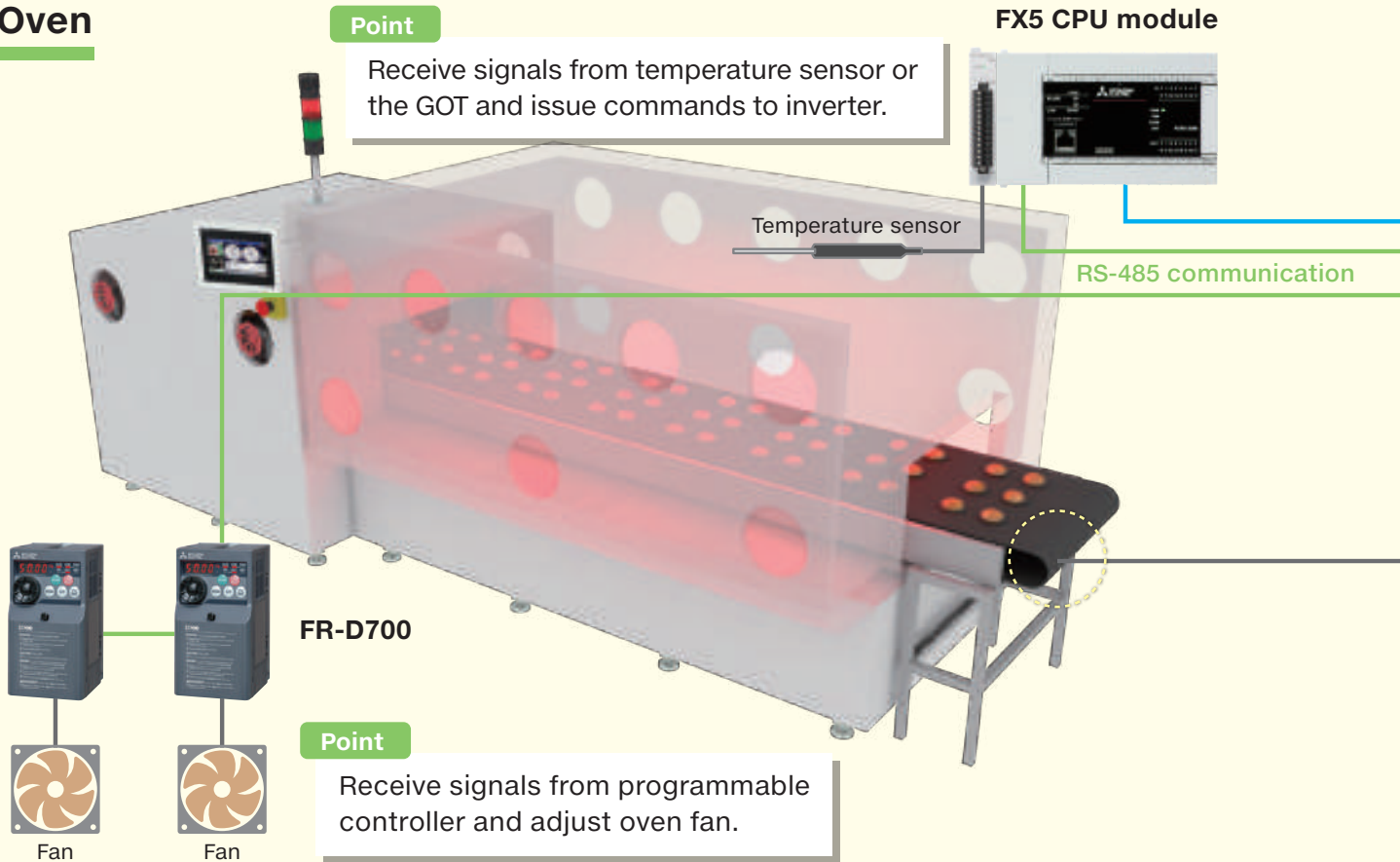

Recommended functions for each application

Optimum excitation control

FR-D700

This control enables the motor to perform with optimum efficiency. More energy saving is possible in applications with variable load torque characteristic such as fan and pump.

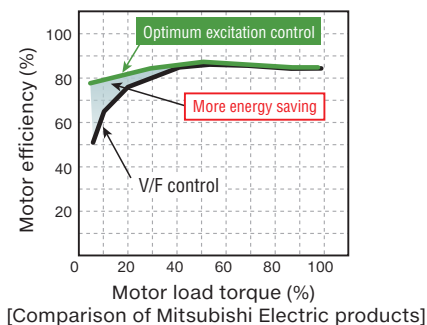

Inverter communication commands

FX5 CPU

Dedicated instructions for Mitsubishi Electric inverter protocol and communication control are built in FX5 CPU module. Connecting an inverter enables simple control of inverter.

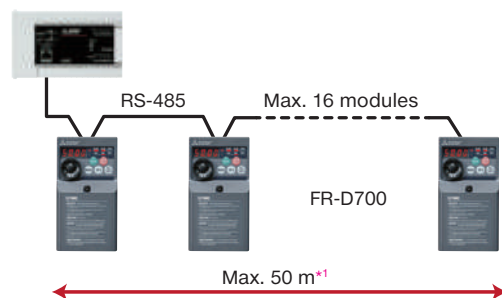

*1 For built-in RS-485 port. 1200 m when configured with FX5-485ADP.

Electric industrial devices for easy automation

GOT SIMPLE



Ethernet

Point

Use recipe function to set baking time according to workpiece type.



FR-D700

Point

Control conveyor speed according to baking time.

GOT SIMPLE



+

Recommended for easy automation!

Programmable Controller MELSEC iQ-F Series

FX5 CPU module



Inverter

FR-D700



Application examples

Fountain



FR-D700
is an ideal choice

Recommended functions: General-purpose magnetic flux vector control, brake transistor built-in connection
A variety of fountain displays are possible by connecting a brake resistor which allows high starting torque and improved braking efficiency during deceleration under general-purpose magnetic flux vector control.

Mixing

FX5U CPU module
is an ideal choice

Recommended function: Analog I/O (with alarm output) control
The FX5U CPU module is equipped with analog input and analog output. No program is required; just set the parameters to start using it.

03

Packaging

Easily build a network with

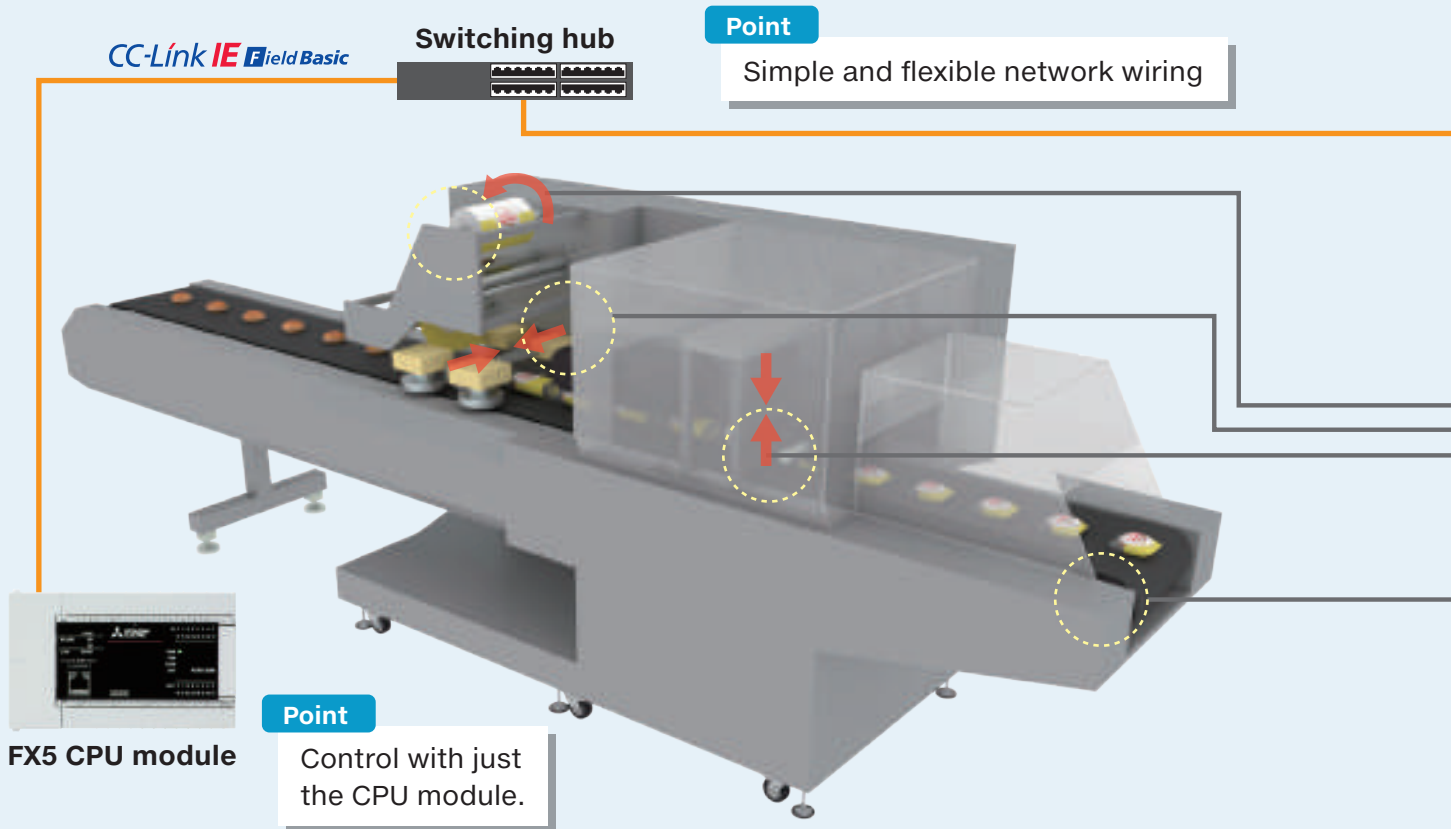

Recommended functions for each application

MR-JE-C

Point table method

Perform positioning operation with the point table method or the indexer method. With the point table method, just set the point table No. and turn on the start signal, and then the positioning operation will start. A continuous operation of the next point table is also possible without stopping. In the indexer method, the travel amount is automatically calculated based on the number of stations set in the parameter.

<MR-JE Series servo amplifier lineup*1>

●: Compatible —: Not compatible

Model	Command interface					
	SSCNET III/H	CC-Link IE Field Basic	MODBUS®/TCP	MODBUS®RTU	Pulse train	Analog voltage
MR-JE-C	—	●	●	●	●	●
MR-JE-B	●	—	—	—	—	—
MR-JE-A	—	—	—	●	●	●

*1 Functions compatible with the latest servo amplifier version are listed. For the details on function compatibility according to the version, please refer to the relevant product manual.

Mitsubishi Electric AC Servo

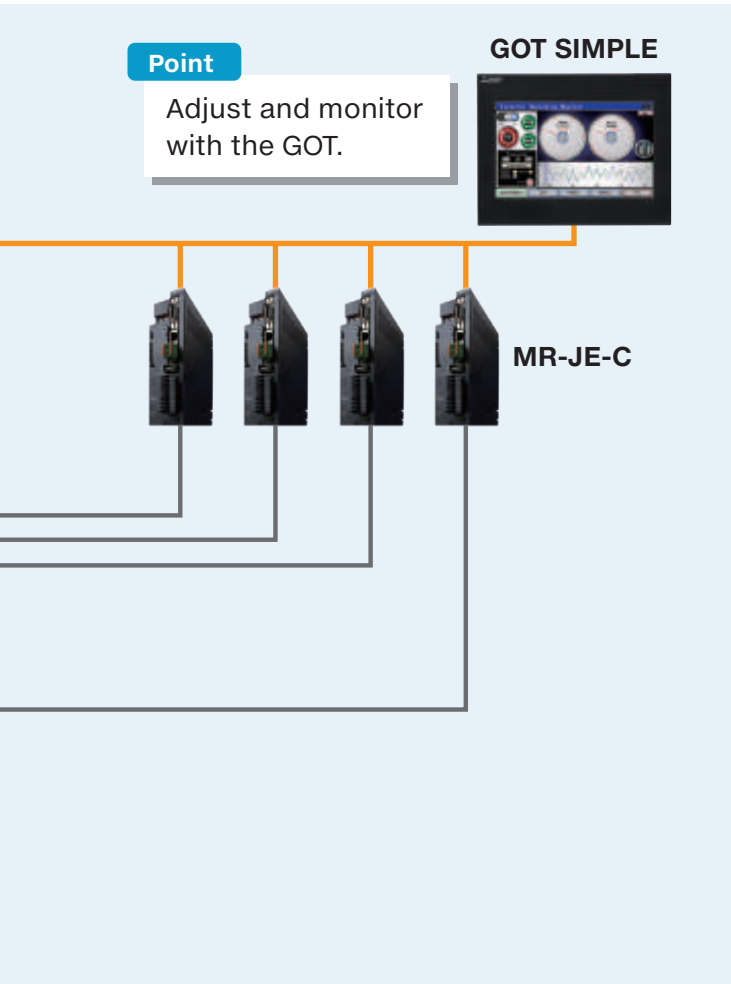

GOT SIMPLE

Recommended for building networks!

Programmable Controller MELSEC iQ-F Series
FX5 CPU module



AC Servo MELSERVO-JE
MR-JE-C



MR-JE-C
is an ideal choice

Application examples

Packaging



Simple synchronous operations including horizontal, vertical, and rotational movements are possible with a start signal to all axes via cyclic transmission. This function can be used to easily build a multi-axis system for packaging, etc.

Machining center



Recommended function: Indexer method

Positioning operation is performed by specifying equally divided stations (up to 255 stations). The travel distance is calculated automatically based on the number of stations and the number of gear teeth on the motor and machine sides set in parameters.

Various Functions in a Small Body



Inverter FR-D700

- Pursuing the easy operation
- Long life and simple maintenance
- Compact and space-saving



Mitsubishi Electric Inverter
For the details of the
FR-D700, please refer to the
catalog on the left.
(L(NA)06055ENG)



FR-D740
Capacity: 0.4 to 7.5 kW



FR-D720
Capacity: 0.1 to 7.5 kW



FR-D720S
Capacity: 0.1 to 2.2 kW



FR-D710W
Capacity: 0.1 to 0.75 kW

Easy wiring to the control circuit

Spring clamp terminals

Spring clamp terminals*1 provide high reliability and easy wiring.

Easy wiring

Wiring is completed only by inserting the dedicated blade terminal of each cable. Without using the blade terminal, the loose wires can also be connected using a flathead screwdriver.

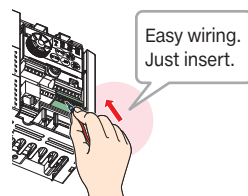

High reliability

Internal terminal contacts are spring-type. Therefore, wires can be protected against loosening or contact faults due to vibrations during operation on a bogie or during transport.

Maintenance-free

No additional screw tightening is required.

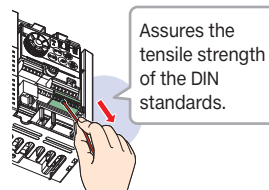

Easily replaceable compact body

Installation size is the same as that of the FR-S500 series which is the smallest model of the Mitsubishi Electric inverter.



Side by side installation saves space

Space can be saved by side by side no clearance installation*2. A DIN rail installation attachment (FR-UDA□□) option can be used.



*1 Main circuit terminal is a screw terminal.

*2 Use the inverter at the surrounding air temperature of 40°C or less.

Password function

Registering a 4-digit password can limit parameter read/write. It is effective for parameter setting protection.



Long-life design

The design life of the cooling fan has been extended to 10 years^{*1}. The life of the fan can be further extended utilizing the ON/OFF control. The design life of the capacitors has been extended to 10 years^{**2} by adopting a capacitor that endures about 5000 hours at 105°C surrounding air temperature.

Estimated service lifespan of the long-life parts

Components	Estimated lifespan of the FR-D700	Guideline of JEMA ³
Cooling fan	10 years	2 to 3 years
Main circuit smoothing capacitor	10 years	5 years
Printed board smoothing capacitor	10 years	5 years

Easy replacement of cooling fan

A cooling fan is provided on top of the inverter of all capacities requiring a cooling fan (1.5 K or more). A cooling fan can be easily replaced without disconnecting main circuit wires.



Compact yet high performance

■ General-purpose magnetic flux vector control

General-purpose magnetic flux vector control and auto tuning functions are available. These functions ensure the applications that require high starting torque, such as washing machines, agitators, and transfer machines including conveyors, hoists, and elevators.

- High torque of 150% /1 Hz is realized (when the slip compensation function is valid).
- Auto tuning

With our “non-rotation” auto tuning function the motor constant (R1) can be automatically calculated.

■ Brake resistor can be connected

A brake transistor is built-in to the 0.4 K or more. Connecting an optional brake resistor increases regeneration capability.

It is useful for deceleration time reduction of a machine with a large inertia, such as fan, and operation of lift, etc.

■ Optimum excitation control

The excitation current is constantly adjusted to its optimum value to drive the motor most efficiently. With a small load torque, a substantial energy saving can be achieved.

Easy-to-read operation panel makes setup and adjustment convenient

■ Enclosure surface operation panel FR-PA07

The operation panel enables inverter operation and monitoring of frequency setting from the enclosure surface.



■ Improve the operability by connection with GOT

The parameters and output frequency of the inverter can be monitored on a graphical and easily-to-read screen of the GOT. Since the details of alarms can be checked, it is convenient when problems occur.

■ Parameter unit FR-PU07

The parameter unit features helpful settings such as direct input with ten-key pad, operating status display, and help function. Eight languages are supported. Parameter settings for up to three units can be saved.



RS-485 communication^{*4}

^{*1} Surrounding air temperature: annual average 40°C (free from corrosive gas, flammable gas, oil mist, dust and dirt)
Since the design life is a calculated value, it is not a guaranteed value.

^{**2} Output current: 80% of the inverter rated current

^{*3} Excerpts from “Periodic check of the transistorized inverter” of JEMA (Japan Electrical Manufacture’s Association)

^{*4} Connect the cable to the RS-422 interface of GOT SIMPLE.

See page 22 for more interactive functions with GOT. ▶▶▶

The next level of industry



Programmable Controller **MELSEC iQ-F** series

- Outstanding performance
- Intuitive programming environment
- Superior drive control



For the details of the MELSEC iQ-F Series, please refer to the catalog on the left. (L(NA)08428ENG)



FX5U

32 to 256 control points*1
Terminal block type



FX5UC

32 to 256 control points*1
Connector type



32 to 256 control points*1
Spring clamp terminal block type

Easily build a positioning system

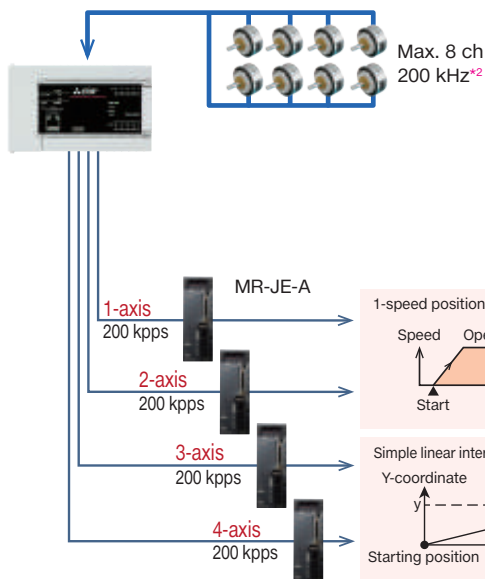

■ Positioning capable of 20 μs high-speed start

FX5U CPU module is equipped with high-speed counter function using 8 high-speed pulse input channels and built-in positioning function using 4-axis pulse output (200 kpps). In addition to conventional interrupt stop operation and variable speed operation, new functions including the table operation and simple linear interpolation operation enhance operability.

Example of packaging device by using built-in positioning

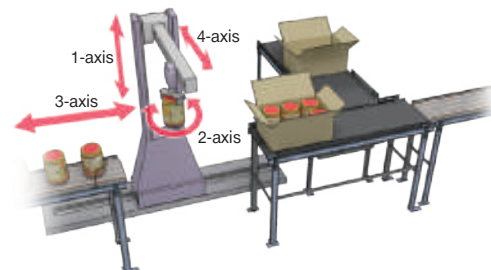

*1 A maximum 512 I/O control points, including remote I/O, is realized.

*2 6 ch 200 kHz+2 ch 10 kHz only for FX5U-32M and FX5UC-32M

Build a high-speed and powerful positioning system

Simple Motion module

FX5-40SSC-S **FX5-80SSC-S**

The Simple Motion module is equipped with a 4/8-axis positioning function compatible with SSCNET III/H.

By combining linear interpolation, 2-axis circular interpolation, constant quantity feed, and continuous path control in a table-based program, the module can be used for a variety of applications.

Main functions

- Linear interpolation
- Circular interpolation
- Continuous path control
- S-curve acceleration/ deceleration

Application examples

- Sealing system
- Palletizer
- Grinding system

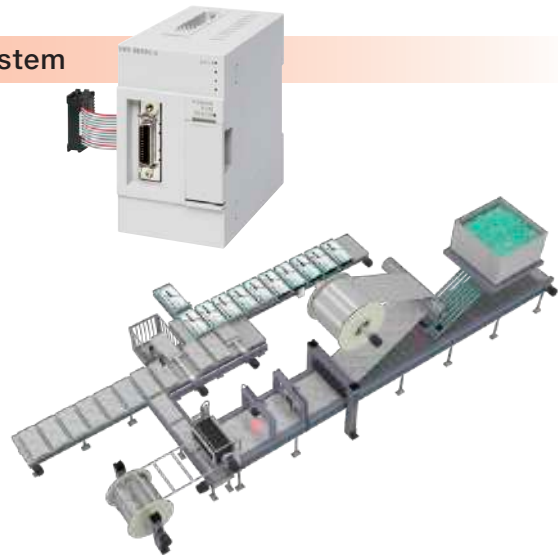

Powerful functions on a compact platform

By starting with parameter settings and the sequence program, the simple motion modules can realize a variety of motion control including positioning control, advanced synchronous control, cam control and speed-torque control.

Synchronous control

In addition to synchronous control that replaces machine mechanisms such as gears, shafts, transmissions, and cams with software, functions such as cam control, clutch and cam auto-generation are easily achieved. Since synchronous control can be started and stopped for each axis, programs can contain both synchronous control axes and positioning control axes.

Up to four axes*1 can be synchronized as the synchronous encoder axis enabling use with a variety of systems.

- Use synchronous control and cam control to build a system perfect for your equipment.
- Register up to 64 types*2 of cam patterns to respond to any type of packaging needs.
- Perform continuous operation without stopping the workpiece operation.

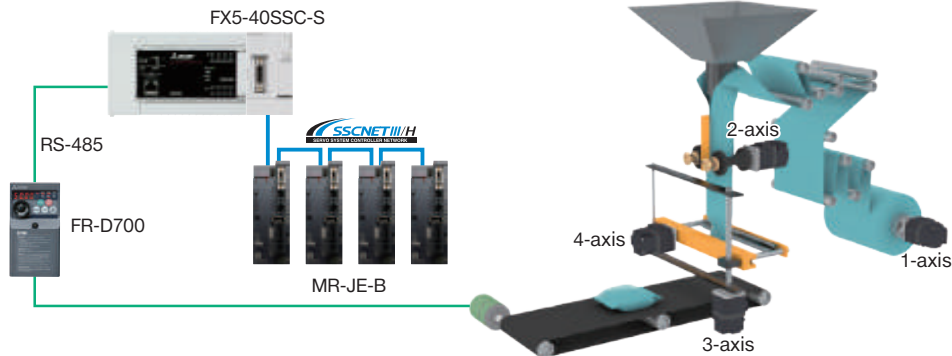

Mark detection function

The cutter axis deviation can be compensated by detecting a mark on the workpiece, so the workpiece can be cut at a constant position.

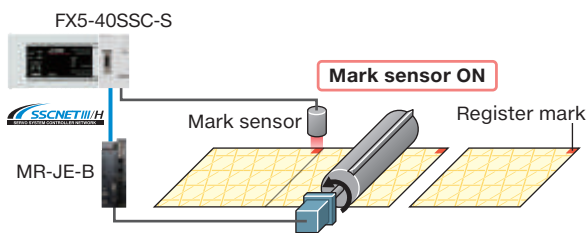

Cam data auto-generation

Easily program and automatically generate difficult cam data for rotary cutters just by inputting the sheet length, synchronization width, and cam resolution, etc. By saving the cam data in the cam save area, even if the power is turned OFF, the previous cam data can be used. Use this function to shorten the system start up time and realize multi-product production.

Item	FX5-40SSC-S	FX5-80SSC-S
Memory capacity	Cam save area	64 k bytes
	Cam load area	128 k bytes
Number of registered cams*3	Cam save area	Up to 64
	Cam load area	Up to 128
		Up to 256

*1 FX5-80SSC-S: 8 axes

*2 FX5-80SSC-S: 128 types

*3 The maximum number of registered cams varies depending on the memory capacity, cam resolution, and number of coordinates. For the details, please refer to the relevant product manual.

See page 22 for more interactive functions with GOT. ▶▶▶

Reliable basic performance, advanced ease-of-use



AC Servo

MITSUBISHI SERVO AMPLIFIERS & MOTORS MELSERVO

- High-precision tuning
- High functions for various applications
- Eco-friendly performance



For the details of the MELSERVO-JE, please refer to the catalog on the left. (L(NA)03086ENG)



MR-JE-A
General-purpose interface compatible servo amplifier



MR-JE-B
SSCNET III/H compatible servo amplifier



MR-JE-C
Ethernet compatible servo amplifier



HG-KN Series
Small capacity, low inertia
Capacity: 100 to 750 W



HG-SN Series
Medium capacity, medium inertia
Capacity: 0.5 to 3 kW



Fast, Trouble-Free Setup

Advanced one-touch tuning function

JE-A JE-B JE-C

Servo gain adjustment is complete just by turning on the one-touch tuning function. With this function, machine resonance suppression filter, advanced vibration suppression control II^{*1}, and robust filter are automatically adjusted to maximize your machine performance. Moreover, a new method allows to create an optimum tuning command inside the servo amplifier. Use this function to further reduce the adjustment time.

Adjust the servo gain just by pressing the "Start" button on one-touch tuning window of MR Configurator2.

Adjust the servo gains just by pressing the buttons on the front of the servo amplifier^{*2}.

Adjust vibration suppression control and robust filter with one touch.

Exactly matched. High-speed positioning.

—: Command - -: Actual operation

Absolute position detection system

JE-B JE-C

The servo motor encoder can be used as an absolute position encoder. Easily build an absolute position detection system.

^{*1} Advanced vibration suppression control II automatically adjusts one frequency.

^{*2} JE-A only.

■ **Large capacity drive recorder**

JE-A JE-B JE-C

Servo data such as motor current and position command before and after the alarm occurrence are stored in non-volatile memory of the servo amplifier. Reading the servo data on MR Configurator2 helps you analyze the cause of the alarm.

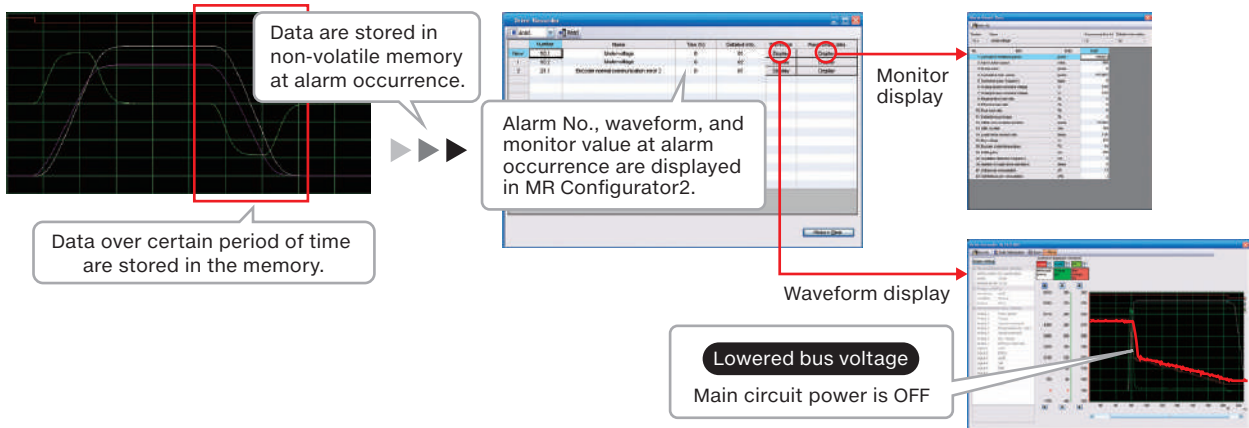

High performance

■ **SSCNET III/H**

JE-B

MR-JE-B is compatible with 150 Mbps full duplex high-speed optical network SSCNET III/H. System response is dramatically improved.

■ **Deterministic and Synchronized Communication**

JE-B

Complete deterministic and synchronized communication is achieved with SSCNET III/H, offering technical advantages in machines such as printing and food processing machines that require synchronous accuracy.

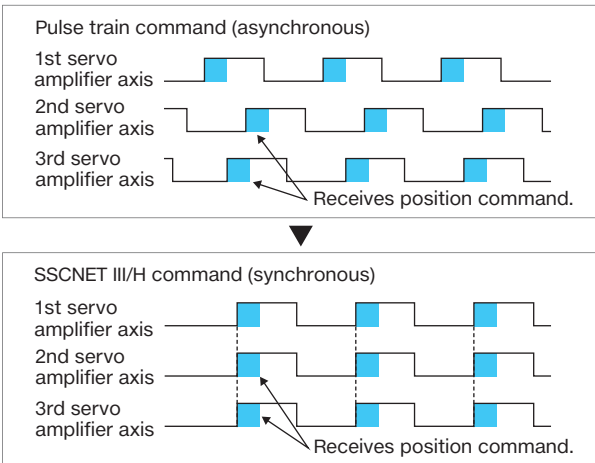

■ **Fast and accurate**

JE-A JE-B JE-C

The dedicated engine enables speed frequency response of 2.0 kHz, shortening the tact time.

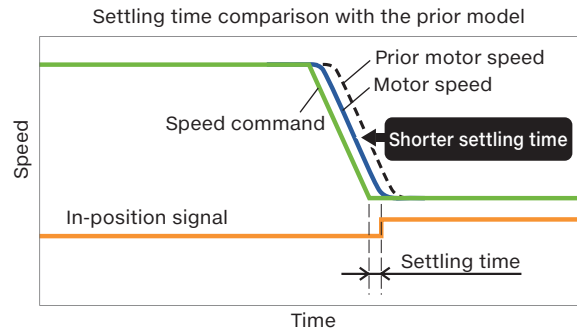

■ **High-resolution encoder**

JE-A JE-B JE-C

The servo motor is equipped with 131,072 pulses/rev (17-bit) high-resolution encoder, achieving high accuracy.



Simplify your system

■ **Built-in positioning function**

JE-A JE-C (future support)

AC servos with the built-in positioning function can be connected to GOT for positioning and adjustment.

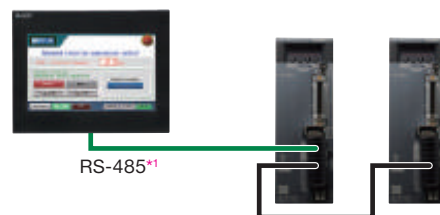

*1 Connect the GOT SIMPLE interface to RS-422.

See page 22 for more interactive functions with GOT. ▶▶▶

The ideal front-end for your system

Benefits of using GOT with Mitsubishi Electric industrial devices



Graphic Operation Terminal

GOT SIMPLE

Graphic Operation Terminal

- Reduce design, setup, and maintenance cost
- Add value to your installation and machine with selection of convenient functions
- Increase work efficiency by using interactive functions with Mitsubishi Electric industrial devices



For the details of the GOT SIMPLE Series, please refer to the catalog on the left. (HIME-L076)



GS2110-WTBD
10 inch WVGA Touch panel HMI



GS2107-WTBD
7 inch WVGA Touch panel HMI

Easily collect and display data of industrial devices

■ Logging function/historical trend graph

GOT manages the data of all connected industrial devices. The data can be collected at an arbitrary timing, and displayed in a graph. Use this function to analyze data and provide feedback, etc.

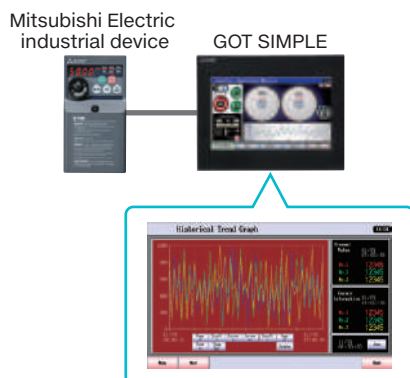

Display industrial devices alarms

■ Alarm function

GOT displays alarms of connected industrial devices as well as the alarms occurred on the GOT.

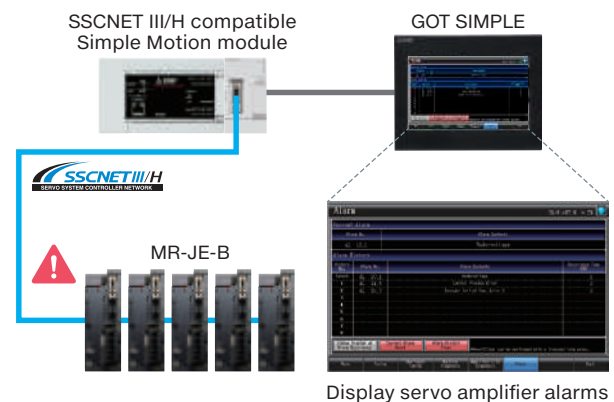

Display servo amplifier alarms

Back up important programs

Backup/Restoration function

Sequence programs can be replaced even without a personal computer. When the programs and parameters are backed up to GOT*¹, the data and machine operation can instantly be restored even if an unexpected failure occurs.

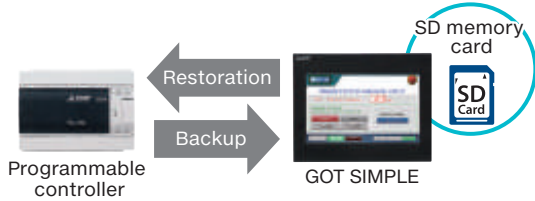

Easy startup, adjustment of industrial devices

FA transparent function

The GOT acts as a transparent gateway to enable programming, start up, and adjustment of Mitsubishi Electric industrial devices.

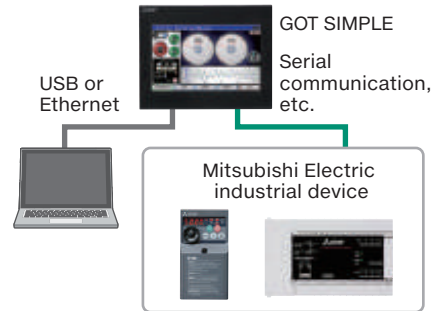

Easily collect data from connected devices

Device data transfer function

Using GT Works3, simply set source devices, destination devices, and triggers and you can transfer data between industrial devices. Data on the connected devices can be collected in the programmable controller without a sequence program.

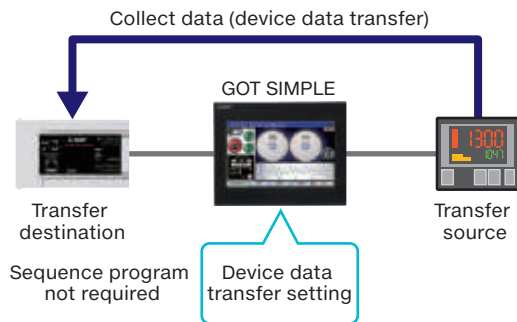

Increase efficiency of maintenance work

Reading/writing resource data

The GOT resource data can be read out to the personal computer, corrected, and then written back*². The efficiency of maintenance work is enhanced as there is no need to exchange data with an SD memory card.

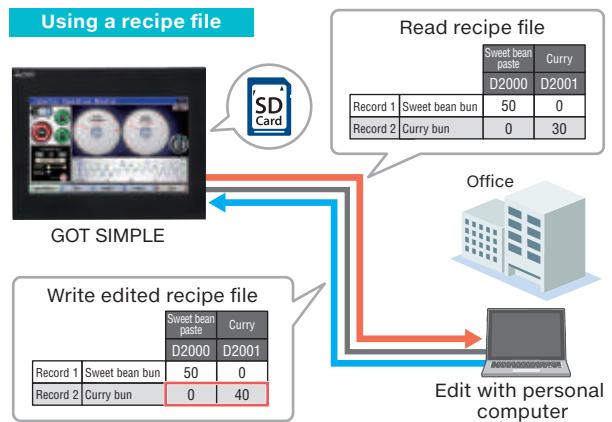

Reduce the risk of unauthorized access via the network

IP filter function

Registering the IP address of the device which can access the GOT restricts the access from unauthorized devices.

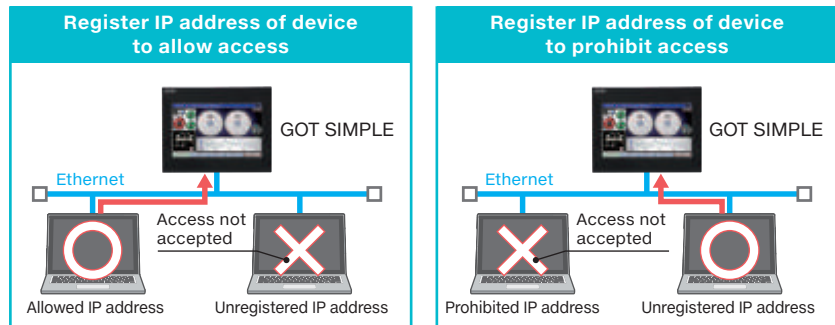

*¹ A separate SD memory card is required.

*² For the details on resource data that can be read and written, please refer to the GT Designer3 (GOT2000) Screen Design Manual.

Easily exchange data with FTP

File transfer function

By using GOT, production results and alarm logs can be stored in an SD memory card of the GOT (FTP client) and sent to a personal computer (FTP server). The GOT can also receive the data from the personal computer.

By using the GOT as an FTP server, files can be read to and written from the personal computer that acts as an FTP client. (FTP server function)

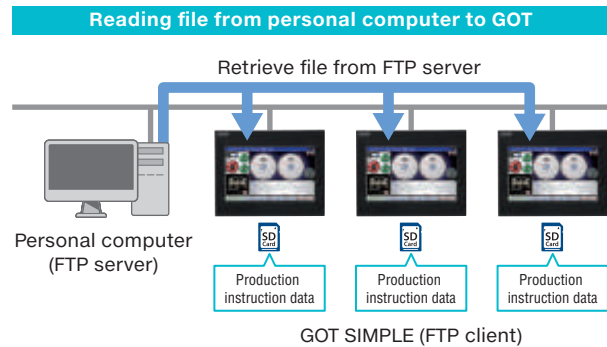
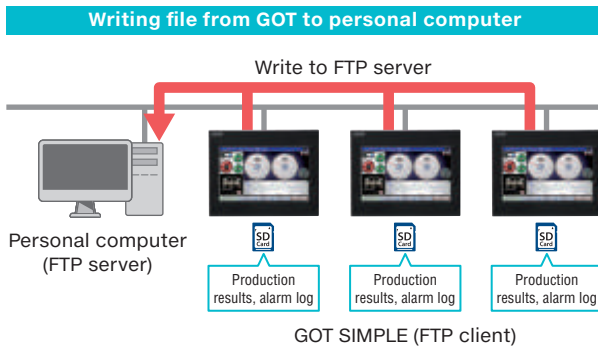

Simple, easy-to-understand setup

Recipe function & recipe display (record list)

GOT saves the recipe information (device values) such as material blend and machine conditions. You can change the recipe on the GOT and write it to a programmable controller to quickly perform the changeover. Changing recipes (changeover) is easy on a user-created screen or on the utility screen. The users can easily create screens by using the recipe display (record list).

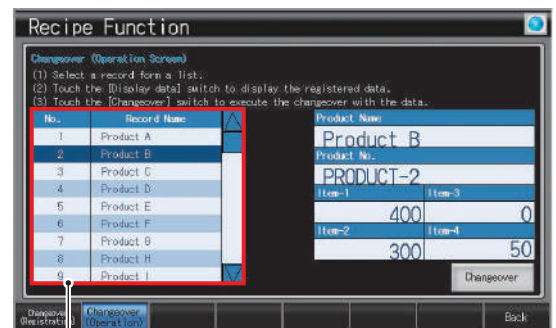
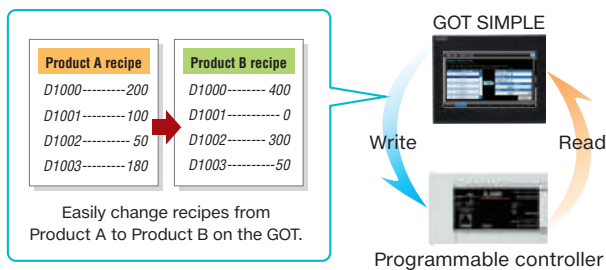

List of records created with recipe display

Suitable even for narrow spaces

Vertical display

The GOT supports vertical display enabling use in narrow operation panels, and helping to downsize system.

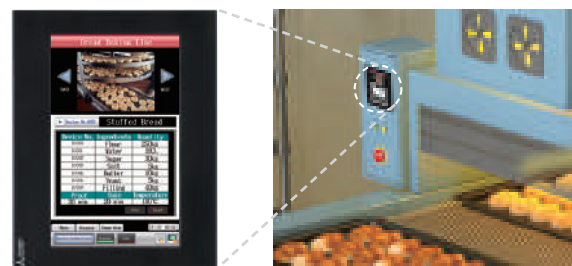

Enhanced interactive functions with drive control

+ AC servo



■ One-touch tuning function/tuning function

An adjustment screen equivalent to the MR Configurator2 adjustment function can be displayed on the GOT, and used to adjust the servo amplifier gain parameters.

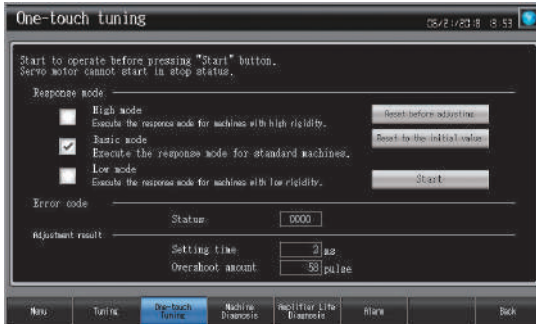

One-touch tuning screen*1



Tuning screen*1

■ Machine diagnosis function/servo amplifier life diagnosis function

A diagnosis screen equivalent to the MR Configurator2 maintenance function can be displayed on the GOT, and used to confirm the servo amplifier machine diagnosis information and state of service parts.

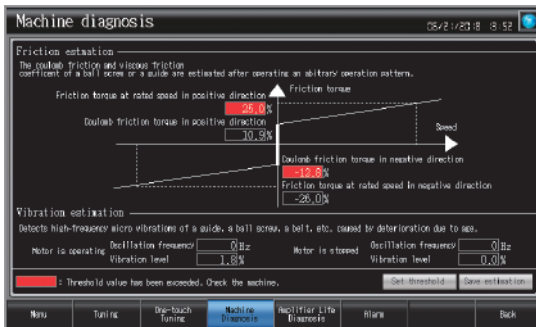

Machine diagnosis screen*1

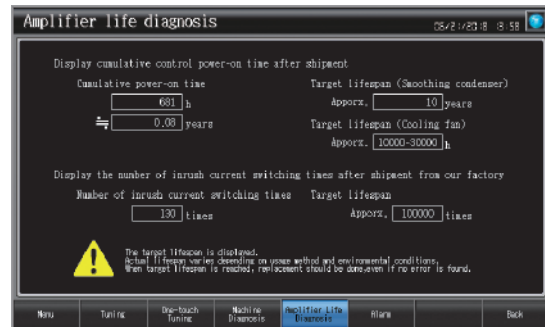

Amplifier life diagnosis screen*1

Enhanced interactive functions with drive control

+ Inverter



■ Parameter setting/operation and monitoring

The inverter simple mode parameters can be adjusted, and the current output frequency, output current, and output voltage values, etc., can be monitored with the GOT.



Parameter setting screen*2

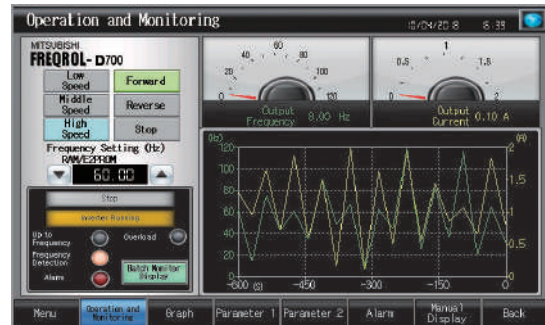

Operation and monitoring screen*2

*1 Ready-to-use sample screens are available.

*2 Parameters and devices can be monitored by setting them on the screen. The above is the example of created screens.

The actual color may differ slightly from the pictures in this catalog.
The actual display may differ from what are shown on GOT screen images.

• Trademarks

ETHERNET is a registered trademark of Xerox Corporation.

MODBUS is a registered trademark of SCHNEIDER ELECTRIC USA, INC.

SD and SDHC Logos are registered trademarks or trademarks of SD-3C, LLC.

All product and company names used herein are either trademarks or registered trademarks of their respective owners.

Precautions before use

This publication explains the typical features and functions of the products herein and does not provide restrictions or other information related to usage and module combinations. Before using the products, always read the product user manuals. Mitsubishi Electric will not be held liable for damage caused by factors found not to be the cause of Mitsubishi Electric; opportunity loss or lost profits caused by faults in Mitsubishi Electric products; damage, secondary damage, or accident compensation, whether foreseeable or not, caused by special factors; damage to products other than Mitsubishi Electric products; or any other duties.

For safe use

- To use the products given in this publication properly, always read the relevant manuals before beginning operation.
- The products have been manufactured as general-purpose parts for general industries, and are not designed or manufactured to be incorporated in a device or system used in purposes related to human life.
- Before using the products for special purposes such as nuclear power, electric power, aerospace, medicine or passenger-carrying vehicles, consult with Mitsubishi Electric.
- The products have been manufactured under strict quality control. However, when installing the products where major accidents or losses could occur if the products fail, install appropriate backup or fail-safe functions in the system.

YOUR SOLUTION PARTNER

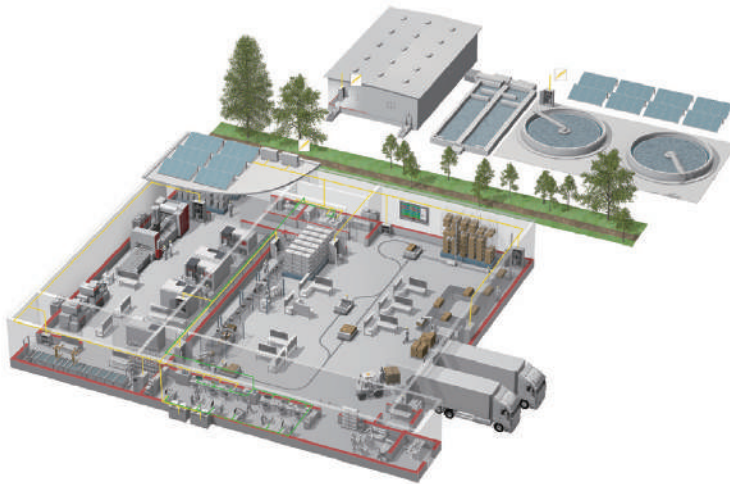

Mitsubishi Electric offers a wide range of automation equipment from PLCs and HMIs to CNC and EDM machines.

A NAME TO TRUST

Since its beginnings in 1870, some 45 companies use the Mitsubishi name, covering a spectrum of finance, commerce and industry.

The Mitsubishi brand name is recognized around the world as a symbol of premium quality.

Mitsubishi Electric Corporation is active in space development, transportation, semi-conductors, energy systems, communications and information processing, audio visual equipment and home electronics, building and energy management and automation systems, and has 237 factories and laboratories worldwide in over 121 countries.

This is why you can rely on Mitsubishi Electric automation solution - because we know first hand about the need for reliable, efficient, easy-to-use automation and control in our own factories.

As one of the world's leading companies with a global turnover of over 4 trillion Yen (over \$40 billion), employing over 100,000 people, Mitsubishi Electric has the resource and the commitment to deliver the ultimate in service and support as well as the best products.



Low voltage: MCCB, MCB, ACB



Medium voltage: VCB, VCC



Power monitoring, energy management



Compact and Modular Controllers



Inverters, Servos and Motors



Visualisation: HMIs



Numerical Control (NC)



Robots: SCARA, Articulated arm



Processing machines: EDM, Lasers, IDS



Transformers, Air conditioning, Photovoltaic systems

* Not all products are available in all countries.

Global Partner. Local Friend.

American Offices

USA Mitsubishi Electric Automation, Inc. 500 Corporate Woods Parkway, Vernon Hills, IL 60061, U.S.A. Tel: +1-847-478-2100	Mexico Mitsubishi Electric Automation, Inc. Mexico Branch Mariano Escobedo #69, Col. Zona Industrial, Tlalnepantla Edo. Mexico, C.P.54030 Tel: +52-55-3067-7511	Brazil Mitsubishi Electric do Brasil Comercio e Servicos Ltda. Avenida Adelino Cardana, 293, 21 andar, Bethaville, Barueri SP, Brasil CEP 06401-147 Tel: +55-11-4689-3000
--	--	--

Asia-Pacific Offices

China Mitsubishi Electric Automation (China) Ltd. No.1386 Hongqiao Road, Mitsubishi Electric Automation Center, Shanghai, China Tel: +86-21-2322-3030	Taiwan SETSUYO ENTERPRISE CO., LTD. 6F, No.105, Wugong 3rd Road, Wugu District, New Taipei City 24889, Taiwan Tel: +886-2-2299-2499	Korea Mitsubishi Electric Automation Korea Co., Ltd. 7F-9F, Gangseo Hangang Xi-tower A, 401, Yangcheon-ro, Gangseo-Gu, Seoul 07528, Korea Tel: +82-2-3660-9530
Singapore Mitsubishi Electric Asia Pte. Ltd. 307 Alexandra Road, Mitsubishi Electric Building, Singapore 159943 Tel: +65-6473-2308	Thailand Mitsubishi Electric Factory Automation (Thailand) Co., Ltd. 12th Floor, SV.City Building, Office Tower 1, No. 896/19 and 20 Rama 3 Road, Kwaeng Bangpongpan, Khet Yannawa, Bangkok 10120, Thailand Tel: +66-2682-6522 to 31	Indonesia PT. Mitsubishi Electric Indonesia Gedung Jaya 11th Floor, JL. MH. Thamrin No.12, Jakarta Pusat 10340, Indonesia Tel: +62-21-3192-6461
Vietnam Mitsubishi Electric Vietnam Co., LTD. Ho Chi Minh Head Office Unit 01-04, 10th Floor, Vincom Center, 72 Le Thanh Ton Street, District 1, Ho Chi Minh City, Vietnam Tel: +84-8-3910-5945	India Mitsubishi Electric India Pvt. Ltd. Pune Branch Emerald House, EL -3, J Block, M.I.D.C., Bhosari, Pune - 411026, Maharashtra, India Tel: +91-20-2710-2000	Australia Mitsubishi Electric Australia Pty. Ltd. 348 Victoria Road, P.O. Box 11, Rydalmere, N.S.W. 2116, Australia Tel: +61-2-9684-7777

European Offices

Germany Mitsubishi Electric Europe B.V. German Branch Mitsubishi-Electric-Platz 1, 40882 Ratingen, Germany Tel: +49-2102-486-0	UK Mitsubishi Electric Europe B.V. UK Branch Travellers Lane, Hatfield, Hertfordshire, AL10 8XB, U.K. Tel: +44-1707-28-8780	Italy Mitsubishi Electric Europe B.V. Italian Branch Centro Direzionale Colleoni - Palazzo Sirio, Viale Colleoni 7, 20864 Agrate Brianza (MB), Italy Tel: +39-039-60531
Spain Mitsubishi Electric Europe B.V. Spanish Branch Carretera de Rubi 76-80-Apdo.420, 08190 Sant Cugat del Valles (Barcelona), Spain Tel: +34-935-65-3131	France Mitsubishi Electric Europe B.V. French Branch 25, Boulevard des Bouvets, 92741 Nanterre Cedex, France Tel: +33-1-55-68-55-68	Czech Mitsubishi Electric Europe B.V. Czech Branch Avenir Business Park, Radlicka 751/113e, 158 00 Praha 5, Czech Republic Tel: +420-251-551-470
Turkey Mitsubishi Electric Turkey A.S. Umraniye Branch Serifali Mahallesi Nutuk Sokak No:5, TR-34775 Umraniye / Istanbul, Turkey Tel: +90-216-526-3990	Poland Mitsubishi Electric Europe B.V. Polish Branch ul. Krakowska 50, 32-083 Balice, Poland Tel: +48-12-347-65-00	Russia Mitsubishi Electric (Russia) LLC St. Petersburg Branch Piskarevsky pr. 2, bild 2, lit "Sch", BC "Benua", office 720; RU-195027 St. Petersburg, Russia Tel: +7-812-633-3497
South Africa Adroit Technologies 20 Waterford Office Park, 189 Witkoppen Road, Fourways, Johannesburg, South Africa Tel: +27-11-658-8100		

The release date varies depending on the product and your region. For details, please contact your local sales office.

MITSUBISHI ELECTRIC CORPORATION

HEAD OFFICE: TOKYO BLDG., 2-7-3, MARUNOUCHI, CHIYODA-KU, TOKYO 100-8310, JAPAN
 NAGOYA WORKS: 1-14, YADA-MINAMI 5, HIGASHI-KU, NAGOYA, JAPAN